



How to Get a Good Soil Sample

Hailin Zhang
 Director, Soil, Water and Forage Analytical laboratory

Gordon Johnson
 Nutrient Management Specialist

Oklahoma Cooperative Extension Fact Sheets are also available on our website at: <http://osufacts.okstate.edu>

Soil tests provide a scientific basis for evaluating available plant nutrients in cropland, pastures, lawns, and gardens. Analyses of soil samples can help farmers and homeowners fine-tune nutrient applications from fertilizers, biosolids, and animal manure. Properly managing the amount of nutrients added to the soil can save money and protect the environment.

Soil nutrients vary by location, slope, soil depth, soil texture, organic matter content, and past management practices, so getting a good soil sample stands out as a major factor affecting the accuracy and usefulness of soil testing. This fact sheet outlines some specific considerations which should be taken into account to get the greatest benefit from soil testing.

Sample Soil at the Right Time

Fields used for production of cultivated crops may be sampled any time after harvest or before planting. Generally, two weeks should be allowed for mailing, analysis, and reporting of results. Additional time may need to be allotted for ordering and application of fertilizers, manure, or lime materials. Noncultivated fields should be sampled during the dormant season. In either case, do not sample immediately after lime, fertilizer, or manure applications because those samples do not represent the true soil fertility.

Fields should be tested annually to measure the available nitrogen pool or as frequently as necessary to gain an understanding of how soil properties may be changing in relation to cultural practices and crop production.

Collect a Representative Sample

Getting a representative sample is simple, but not easy. Research at OSU and other universities has clearly shown that a minimum of 20 cores or small samples taken randomly from the field or area of interest are necessary to obtain a sample which will represent an average of the soil in the field (Figure 1). These cores should be collected in a clean plastic bucket (to avoid metal contamination) and mixed thoroughly by hand. The sample bag should be filled from the mixture. A one pint (OSU soil sample bag full) sample is usually adequate for all tests which might be required. If the sample is too wet to mix, it should be spread out to dry some and then mixed, or sampling should be delayed until the field is drier.

It is important to remember that the sample obtained by the above procedure will be an average of the area sampled. If the area sampled is extremely variable in the soil properties which are going to be tested, then it may be better to separate

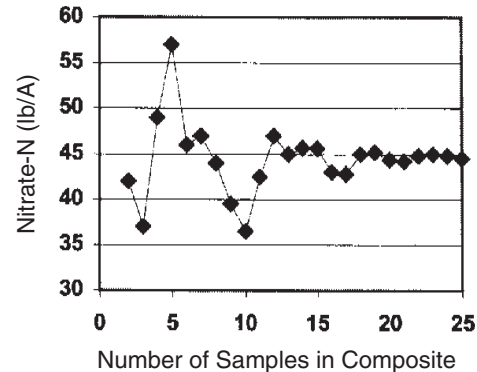

Figure 1. The minimum number of core samples needed to make a representative composite sample is about 20.

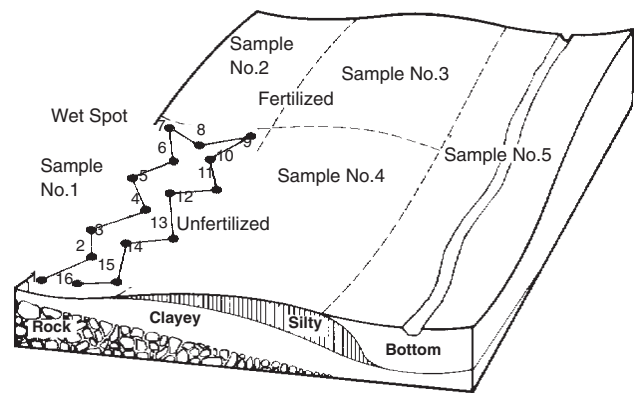

Figure 2. Divide field into uniform sampling areas and follow a random pattern when sampling. Avoid unusual spots and try to obtain a representative sample.

the field into smaller areas, and get a representative (20 cores) sample from each of these areas in order to determine how variable the field is (Figure 2). In this way, it may be possible to treat some areas of the field differently from others and remove variability so that the field can be sampled and treated as a unit in the future. Variability in a field can often be noted by differences in surface soil color and crop growth or yield.

Using only one sample for a large variable field can be very costly. Since the sample represents an average of the

soil in that field, recommendations based on the soil test will likely cause the field to be overfertilized on some parts and underfertilized on other parts. Failure to obtain uniform response to treatments based on a soil test is frequently a result of one sample being used to represent a large variable field.

An example of field variability is shown in Table 1. The range of test values was obtained by testing 40 individual cores taken at random from an “apparently uniform” 80-acre field. The variation is great enough so that for some analyses the average is not a good representation of the field. Areas of the field with the lowest pH, phosphorus, and potassium values will not receive adequate lime or fertilizer if recommendations are based on the average test values.

A single core sample, or spadeful, is extremely risky because it may test anywhere in the range shown for each of the analyses. For example, deficiencies for wheat could range from zero to 37 pounds of P₂O₅ and zero to 34 pounds of K₂O. For alfalfa, which has much greater nutrient requirements, deficiencies could range from zero to 94 pounds of P₂O₅ and zero to 120 pounds of K₂O. This would also affect the amount of nitrogen and lime required. Obviously, unless the 80 acres is divided into less variable units for testing, some areas of the field will receive either too much or too little fertilizer and lime.

In deciding how large an area can be represented by one composite sample (20 cores), the determining factor is not the number of acres involved, but rather, the variability of the area. Some large, uniform fields can be represented well by a single 20-core sample, while some highly variable fields need to be split into two or more smaller areas for testing. Regardless of the field size or main area being sampled, unusual spots in the field (salty or wet spots) should be avoided during the initial random sampling. When unusual spots make up a significant area, they should be sampled separately.

Sample at Proper Depth

Cultivated Fields

For most soil tests the sampling depth is the tillage depth. The reason for this is because most crops have their greatest root activity in the tillage depth. Obtaining a representative sample with regard to depth means that each of the 20 cores taken from an area should be from similar depth, tillage, or

six inches. Soil tests are generally calibrated on the basis of an acre furrow slice, approximately two million pounds of soil in the top six inches.

For deep-rooted nonlegumes such as wheat, bermudagrass, sorghum, and cotton, a separate sample representative of the subsoil should be taken in addition to the tillage depth or six-inch sample. This subsoil sample should represent the layer of soil from 7 to 24 inches below the surface. Because nitrate-nitrogen is mobile in the soil, a test of available nitrogen (and/or chloride and sulfate) in the subsoil sample will provide a more complete picture of available mobile nutrients for these crops (Figure 3) and can save fertilizer expenses.

No-till Fields

Noncultivated fields should be sampled to a depth of six inches, again because this is the effective depth of most treatments and the depth of most root activity. Nutrients from fertilizer, animal manure, and lime can be accumulated on the surface if they are surface applied without incorporation. A set of samples from the top two inches will help identify stratification of nutrients and is especially important for pH determination for no-till fields. If nutrient loss in runoff is the main concern, the two-inch sample is better than a six-inch sample because only the surface inch or two is in direct contact with surface runoff.

Salinity Diagnosis

When salt accumulation is suspected as a cause of poor stand establishment and the sample is being taken after planting, then the depth of sampling should approximate the seeding depth (one to three inches). This is especially important when conditions have been favorable for soluble salts to move upward and accumulate near the surface after planting. Since excess salts are most harmful to germination and seedling vigor, it is this shallow depth which should be tested. At other times during the year, a sample of the entire tillage depth may be most useful to test for salt accumulation.

Send Samples for Analysis

Soil sample bags are available at local county Extension offices. Extension offices will mail your samples to the OSU Soil, Water and Forage Analytical Laboratory and assist you to interpret test results.

Table 1. Variability of an 80 Acre Field Based on Soil Tests of 40 Individual Soil Cores .

Analysis	Soil Test Values	
	Range	Average
pH	4.9-6.3	5.6
Buffer Index	7.1-7.4	7.3
Nitrogen	1-34	11
Phosphorus	23-114	36
Potassium	149-770	306

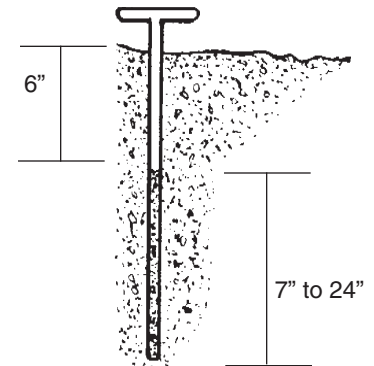

Figure 3. A soil probe is a good tool for obtaining soil samples. Push the tube to the six-inch depth and remove the core. Then take the seven to 24-inch core through the same hole for the subsoil test.

Oklahoma State University, in compliance with Title VI and VII of the Civil Rights Act of 1964, Executive Order 11246 as amended, Title IX of the Education Amendments of 1972, Americans with Disabilities Act of 1990, and other federal laws and regulations, does not discriminate on the basis of race, color, national origin, gender, age, religion, disability, or status as a veteran in any of its policies, practices, or procedures. This includes but is not limited to admissions, employment, financial aid, and educational services.

Issued in furtherance of Cooperative Extension work, acts of May 8 and June 30, 1914, in cooperation with the U.S. Department of Agriculture, Robert E. Whitson, Director of Cooperative Extension Service, Oklahoma State University, Stillwater, Oklahoma. This publication is printed and issued by Oklahoma State University as authorized by the Vice President, Dean, and Director of the Division of Agricultural Sciences and Natural Resources and has been prepared and distributed at a cost of 20 cents per copy. 0702