



Aeration Systems for Flat-Bottom Round Bins

Pete Bloome
Extension Agricultural Engineer

Sam Harp
Manager, OSU Farm Building Information Service

Gerald Brusewitz
Associate Professor of Agricultural Engineering

James Garton
Professor of Agricultural Engineering

Oklahoma Cooperative Extension Fact Sheets are also available on our website at: <http://osufacts.okstate.edu>

Before attempting to select, design, or manage an aeration system one should study the publications, Fact Sheet BAE-1100 "Maintaining Quality of Stored Grain," and Fact Sheet BAE-1101 "Aeration and Cooling of Stored Grain."

Fact sheet BAE-1100 discusses the roles of moisture migration and mold growth in grain spoilage. Methods used to prevent these problems are explained. A good understanding of the principles of grain quality maintenance is essential for successful management of stored grain.

Fact sheet BAE-1101 discusses the importance of choosing the right airflow rate to obtain the desired aeration system capabilities. Power requirements, fan selection, control systems, and management suggestions are also presented.

This fact sheet covers the design or selection of aeration system components for flat-bottom, round grain bins.

Types of Systems

A totally-perforated metal drying floor offers the best air distribution system for flat-bottom grain bins. The totally-perforated floor is elevated approximately 18 inches above the concrete floor of the bin. This area serves as a plenum and is a convenient location for the unloading auger. A totally-perforated floor is illustrated in Figure 1.

Totally-perforated floors are normally installed in bins for the purpose of grain drying. While they provide the best distribution system for aeration, they are also the most expensive. A foundation ring and floor support system must be installed in addition to the perforated floor.

A partially-perforated floor offers the next best alternative and is illustrated in Figure 2. A square section, with side length equal to $\frac{1}{2}$ to $\frac{2}{3}$ of the bin diameter, is recessed approximately 10 inches at the center of the bin. Concrete blocks and 2-inch dimension lumber support sections of perforated floor placed over this area. Air is ducted to this center area, which again serves as a plenum.

No foundation ring is needed and the perforated floor section is easily installed. The central recessed area is easily formed in concrete.

Ducts are commonly used as distribution systems for aeration. If the ducts are set below floor level (flush-floor ducts), a sweep auger may be used for complete bin

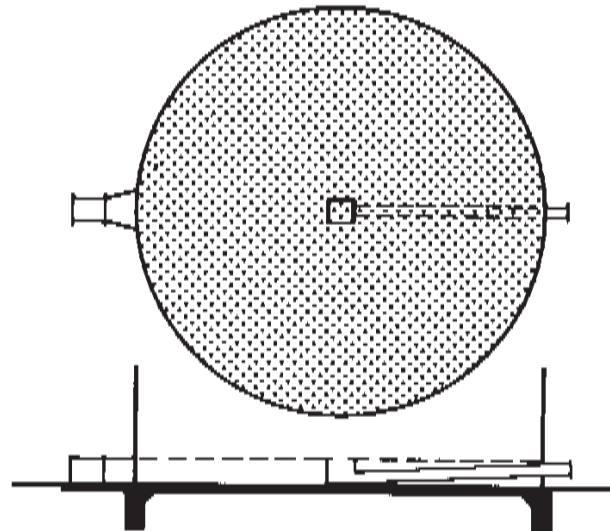

Figure 1. A totally-perforated floor system.

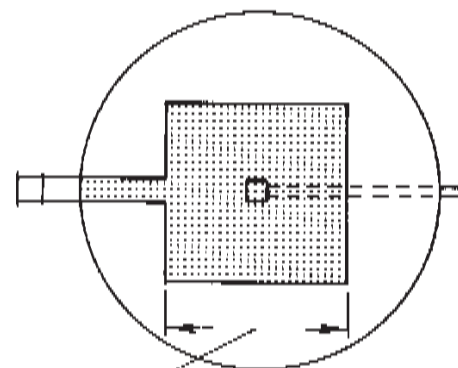

Figure 2. A partially-perforated floor system.

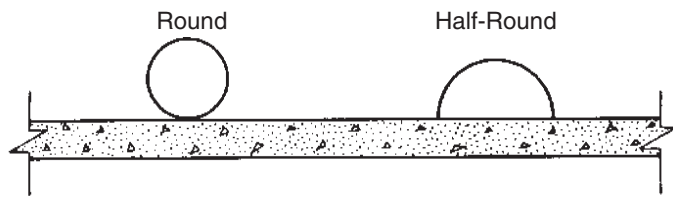

Figure 3. On-floor ducts are usually round or half-round in cross-sections.

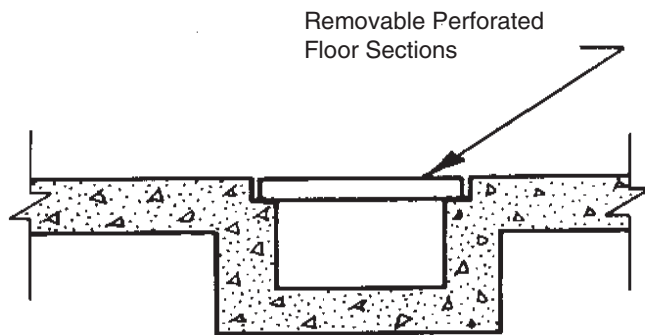

Figure 4. Flush-floor ducts are usually rectangular in cross-section.

unloading. If ducts are placed above the floor (on-floor ducts), manual labor is required to completely empty the bin.

On-floor ducts are usually round or half-round in cross-section and are illustrated in Figure 3. Flush-floor ducts are usually rectangular in cross-section and are illustrated in Figure 4.

Aeration ducts may be placed in a variety of patterns to obtain more uniform air distribution. Common patterns are illustrated in Figure 5. The system illustrated in 5-B provides the best distribution pattern and gives a higher concentration of airflow at the center, often a trouble spot. This pattern is desirable for bin diameters of 24 to 42 feet.

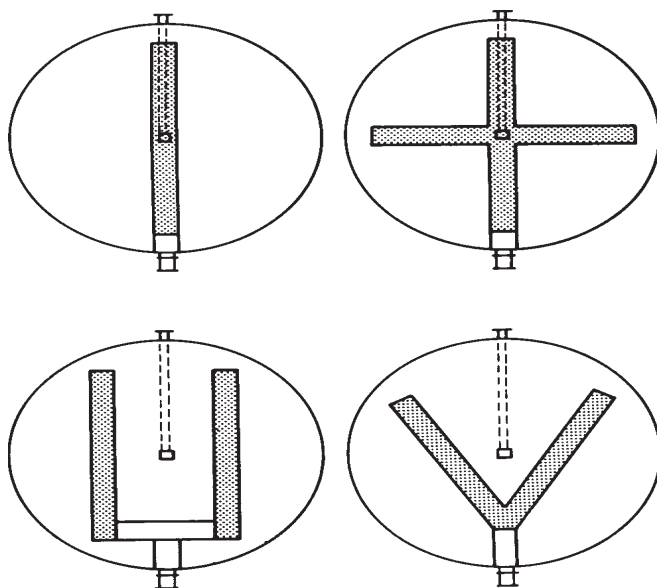

Figure 5. Common patterns for aeration ducts.

Description of Terms

The following terms are used in the design procedure:

Hp = Horsepower

fpm = feet per minute, air velocity;

CFM = cubic feet of air per minute, air volume;

CFM/bU = cubic feet of air per minute per bushel, airflow rate;

static pressure = the pressure against which the fan must operate, expressed as inches of water.

Design Procedure

The design procedure for aeration systems involves the following steps:

1. Determining bin capacity, selecting air-flow rate, and determining total air volume to be delivered;
2. Selecting ducts on the basis of cross-sectional area and surface area;
3. Determining operating static pressure; and
4. Selecting fans to deliver the required air volume when operating against the expected static pressure.

Using Nomographs

Nomographs can simplify the design procedure. Answers are obtained by drawing straight lines on the nomographs instead of solving mathematical equations. Only a straight-edge and sharp pencil are required. While the nomographs may at first appear to be complicated, following the examples will quickly show their advantages.

Determining Air Volume

The required air volume is determined by the chosen airflow rate, in CFM/bu, and the bin capacity in bushels. Nomograph 1 is used to quickly determine bin capacity and air volume if the bin diameter, bin sidewall height or grain depth, and desired airflow rate are known. Bin capacity does not include storage in the roof section. It is assumed the bin will be filled to the eaves making grain depth and bin sidewall height equal.

The choice of airflow rate is an important decision. Higher aeration airflow rates give greater management flexibility and allow the storage of grain with higher moisture content. However, higher aeration airflow rates also require larger ducts, involve higher static pressures, and have greater power requirements. For a complete discussion of airflow rates, see Fact Sheet BAE-1101.

Consider a 30 feet diameter bin with 20 feet sidewall height. On Nomograph 1, if a straight line is drawn from 30 feet diameter (scale A) to 20 feet sidewall height (scale C), it crosses scale B at about 11,300 bushels of bin capacity.

Suppose we wish to provide an airflow rate of $\frac{1}{5}$ (.2) CFM/bu. Drawing a straight line from 11,300 bu. bin capacity (scale B), through $\frac{1}{5}$ CFM/bu. (scale D) and extending the line to scale E gives a total air volume of about 2,300 CFM.

Determining Required Duct Size

When duct distribution systems are used, two critical design factors must be considered; duct cross-sectional area and duct surface area. Recommended maximum duct velocity

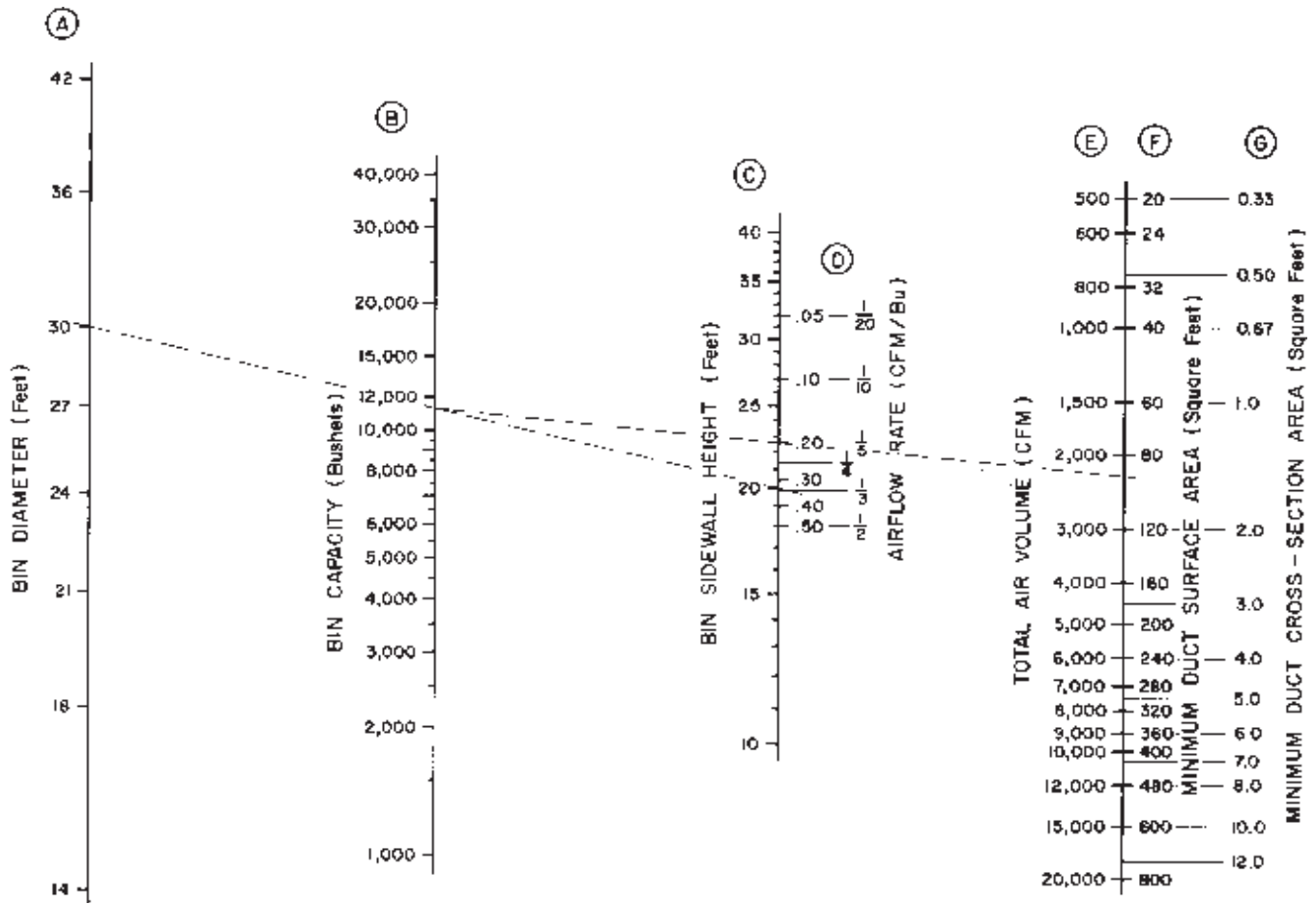

Nomograph 1. Bin capacity, total air volume and minimum duct areas.

is 1,500 fpm. Minimum required duct cross sectional area, in square feet, is total air volume (CFM) divided by 1,500 fpm.

Recommended maximum velocity of air leaving the duct is 25 fpm. Minimum duct surface area, in square feet, is total air volume (CFM) divided by 25 fpm.

Nomograph 1 also gives minimum duct surface area (scale F) and minimum duct cross-sectional area (scale G) when the total air volume is determined. For the air volume of 2,300 CFM, at least 90 square feet of duct surface area (scale F) and at least 1.5 square feet of duct cross-sectional area (scale G) should be provided.

For totally-perforated floor systems, the duct area requirements do not apply. For partially-perforated floor systems, the duct supplying air to the perforated floor must meet the cross-sectional area requirement, but the surface area requirement does not apply. With duct systems, both area requirements must be met.

Table 1 is used to determine the required size of flush-floor ducts. Only the flat top of flush-floor ducts may be calculated as surface area. For our example, choosing a 24-inch width and 10 inch depth gives 1.67 square feet of cross-sectional area and 2.0 square feet of surface area for each foot of length. Since 90 square feet of surface area is required, at least 45 feet of 2-foot wide duct must be provided in the bin. The duct patterns of Figures 5-B, 5-C, or 5-D would have to be used to provide the required surface area.

Table 1. Areas of Flush-Floor Ducts.

Width (inches)	Surface Area (Square feet/foot of length)	Depth of Duct (Inches)					
		6	8	10	12	15	18
6	0.50	0.25	0.33	0.42	0.50	0.63	0.75
8	0.67	0.33	0.44	0.56	0.67	0.83	1.00
10	0.83	0.42	0.56	0.69	0.8	1.04	1.25
12	1.00	0.50	0.67	0.83	1.00	1.25	1.50
14	1.17	0.58	0.78	0.97	1.17	1.46	1.75
16	1.33	0.67	0.89	1.11	1.33	1.67	2.00
18	1.50	0.75	1.00	1.25	1.5	1.88	2.25
20	1.67	0.83	1.11	1.39	1.6	2.08	2.50
22	1.83	0.92	1.22	1.53	1.83	2.29	2.75
24	2.00	1.00	1.33	1.67	2.00	2.50	3.00

Table 2 is used to determine the required size of on-floor ducts. For round on-floor ducts the surface area is calculated at 80 percent effective to account for the portion of the duct in contact with the floor. For half-round, on-floor ducts, only the rounded portion of the duct is exposed to grain and can be calculated as surface area.

An 18-inch diameter, round duct has 1.8 square feet of cross-sectional area and 3.8 square feet of surface area for each foot of length. Since 90 square feet of surface area is required in the example, 24 feet of 18-inch diameter, round duct will meet the minimum area requirements.

Table 2. Areas of On-Floor Ducts.

Diameter (inches)	Round		Half-Round	
	Cross-Sectional Area (Sq. ft.)	Surface Area (Square ft./feet of length)	Cross-Sectional Area (Sq. ft.)	Surface Area (Square ft./feet of length)
6	0.20	1.26	0.10	0.79
8	0.35	1.68	0.17	1.05
10	0.55	2.09	0.27	1.31
12	0.79	2.51	0.39	1.57
15	1.23	3.14	0.61	1.96
18	1.77	3.77	0.88	2.36
20	2.18	4.19	1.09	2.62
24	3.14	5.03	1.57	3.14
30	4.91	6.28	2.45	3.93
36	7.07	7.54	3.53	4.71

A 24-inch diameter, half-round duct has 1.6 square feet of cross-sectional area and 3.1 square feet of surface area for each foot of length. Again, since 90 square feet of surface area is required in the example, 29 feet of 24-inch diameter, half-round duct will meet the minimum area requirements.

Duct sizes are also selected to provide a convenient duct pattern. Often the duct is selected with cross sectional area larger than required in order to reduce the length of duct necessary to meet the surface area requirement.

Determining Operating Pressure

Nomographs 2 and 3 are used to determine the expected operating static pressure. Nomograph 2 is used when corn or soybeans is the grain to be aerated, and Nomograph 3 is used for wheat, grain sorghum, oats, barley, or rye. When the system will be used for more than one grain, design for the grain that gives the highest operating pressure.

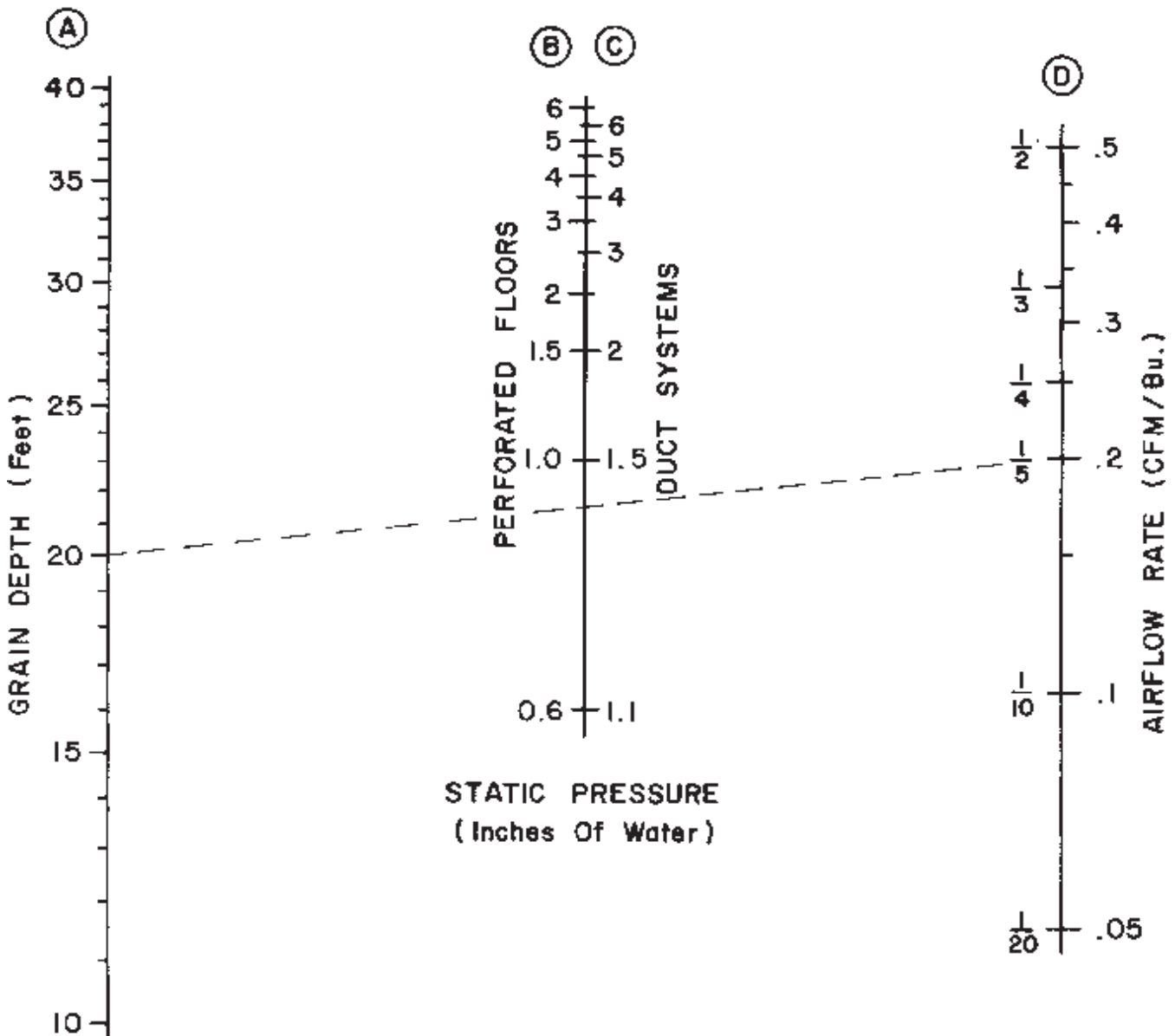

Nomograph 2. Expected static pressure for corn or soybeans.

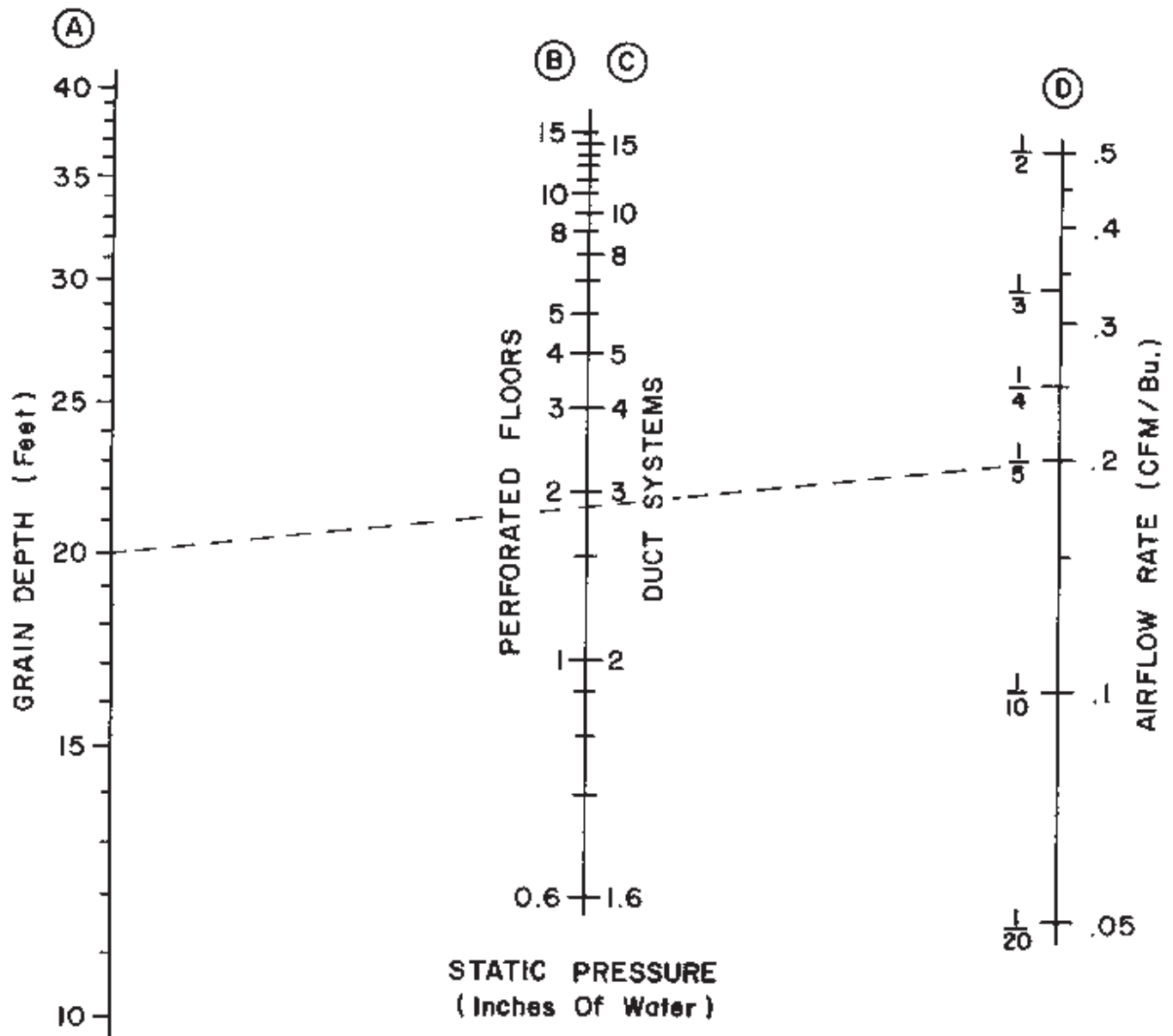

Nomograph 3. Expected static pressure for wheat, grain sorghum, oats, barley, or rye.

Nomographs 2 and 3 are used by drawing a straight line between grain depth (scale A) and air-flow rate (scale D). Total expected operating pressures for perforated floor systems are read from scale B and for duct systems are read from scale C.

If the grain bin of our example will be used for storage of corn or soybeans (Nomograph 2), the expected operating pressure is about 0.9 inches of water with a perforated floor system and about 1.4 inches of water with a duct distribution system. If the bin will be used for storage of wheat, grain sorghum, oats, barley, or rye (Nomograph 3), the expected operating pressure is about 1.8 inches of water with a perforated floor system and about 2.8 inches of water with a duct distribution system.

Selecting Fans

Fans are selected from the manufacturer's rating curves or tables to deliver the required air volume when operating against the expected static pressure. Axial fans (propeller-type) are commonly used for aeration since they produce high air volumes at low static pressures. However, air volumes delivered by axial fans fall off rapidly as static pressures increase through the 3.5 to 5.0-inch range. Above this range, centrifugal fans with backward-inclined blades must be used. In special designs, centrifugal fans will operate efficiently at static pressures of 20 inches or more.

Centrifugal fans operate with less noise than axial fans and should be used whenever fan noise may be a nuisance to neighbors. Centrifugal fans of 3 Hp or less cost 2 to 3 times as much as axial fans of the same Hp rating. Above 5 Hp, centrifugal fans cost 1.5 to 2 times as much as axial fans of the same Hp rating.

The lowest priced fan which will deliver the required air volume when operating at the expected static pressure is, of course, the most economical fan to buy. However, the most economical fan to operate is the fan with the lowest power consumption, measured in watts, while delivering the required air volume at the expected static pressure. Nominal horsepower rating is not a good measure of power consumption.

While final fan selection must be made from manufacturer's data, an estimate of the power requirement may be helpful for planning purposes. Nomograph 4 is used to estimate the power requirement, assuming a fan efficiency of 50 percent. A straight line is drawn between total air volume (scale A) and expected operating pressure (scale C) to determine the

approximate power requirement on scale B.

Our example calls for an air volume of 2300 CFM. If the operating pressure is 1.4 inches, the power requirement is about 1.0 Hp. If the operating pressure is 2.8 inches, the power requirement is about 2.0 Hp.

When selecting fans, consult the data from several manufacturers. Tables 3 and 4 present typical performance data for axial and centrifugal fans, respectively. One manufacturer's 3

Table 3. Typical Performance Data for Axial Fans

Hp	RPM	Static Pressure (inches of water)					
		0.5	1.0	1.5	2.0	3.0	4.0
CFM							
1	3450	2,880	2,635	2,360	1,935	810	455
3	3450	7,000	6,400	5,700	5,200	3,700	2,200
5	3450	9,700	9,100	8,600	8,000	6,500	4,600
7 1/2	3450	12,800	12,300	11,600	11,000	9,800	7,400

Hp fan may be well matched to one's needs while another's 3 Hp fan may not. Fan performance data should be certified in accordance with standard test codes adopted by the Air Moving and Conditioning Association Inc. and bear the AMCA seal.

Further Examples

A round, on-floor duct distribution system is desired for a 24-foot diameter bin with 18-foot sidewalls which will be used to store wheat. An airflow rate of 1/4 (.25) CFM/bu. is desired. Nomograph 1 gives the following values: 6500 bu. bin capacity, 1600 CFM air volume; 64 square feet minimum duct surface area and 1.1 square feet minimum duct cross-sectional area.

Consulting Table 2 shows any round duct with diameter of at least 15 inches will meet the cross-sectional area requirement. A 15-inch diameter round duct must be 21 feet long (63/3.1) to meet the surface area requirement. Nomograph 3 gives an expected static pressure of 2.8 inches with an airflow rate of .25 CFM/bu. through 18 feet of wheat with a duct distribution system. From Nomograph 4, the approximate power requirement for 1600 CFM at a static pressure of 2.8 inches is about 1.4 Hp.

As a final example, suppose a farmer wishes to provide 1/2 (.5) CFM/bu for quick cooling of damp grain sorghum during harvest. The bin is 27 feet in diameter, has 20-foot sidewalls, and is equipped with a totally-perforated floor.

Nomograph 1 shows a bin capacity of 9,000 bushels and an air volume of 4,500 CFM. Since a totally perforated floor will

Table 4. Typical Performance Data for a Centrifugal Fan*

CFM	Static Pressure (inches of water)						
	2.0	4.0	6.0	8.0	10.0	12.0	14.0
	RPM HP	RPM HP	RPM HP	RPM HP	RPM HP	RPM HP	RPM HP
1013	1224 .068	1638 1.25	1968 1.87	2252 2.54	2505 3.27	2737 4.03	2951 4.63
1520	1364 1.15	1753 1.96	2064 2.77	2332 3.60	2574 4.47	2794 5.37	3000 6.30
2026	1527 1.81	1894 2.89	2190 3.94	2446 4.99	2679 6.05	2891 7.14	3090 8.25
2532	1708 2.72	2050 4.07	2334 5.40	2584 6.71	2805 8.01	3010 9.30	3204 10.6

*This table is abbreviated. Intermediate static pressures and a much larger range of CFM values are normally shown.

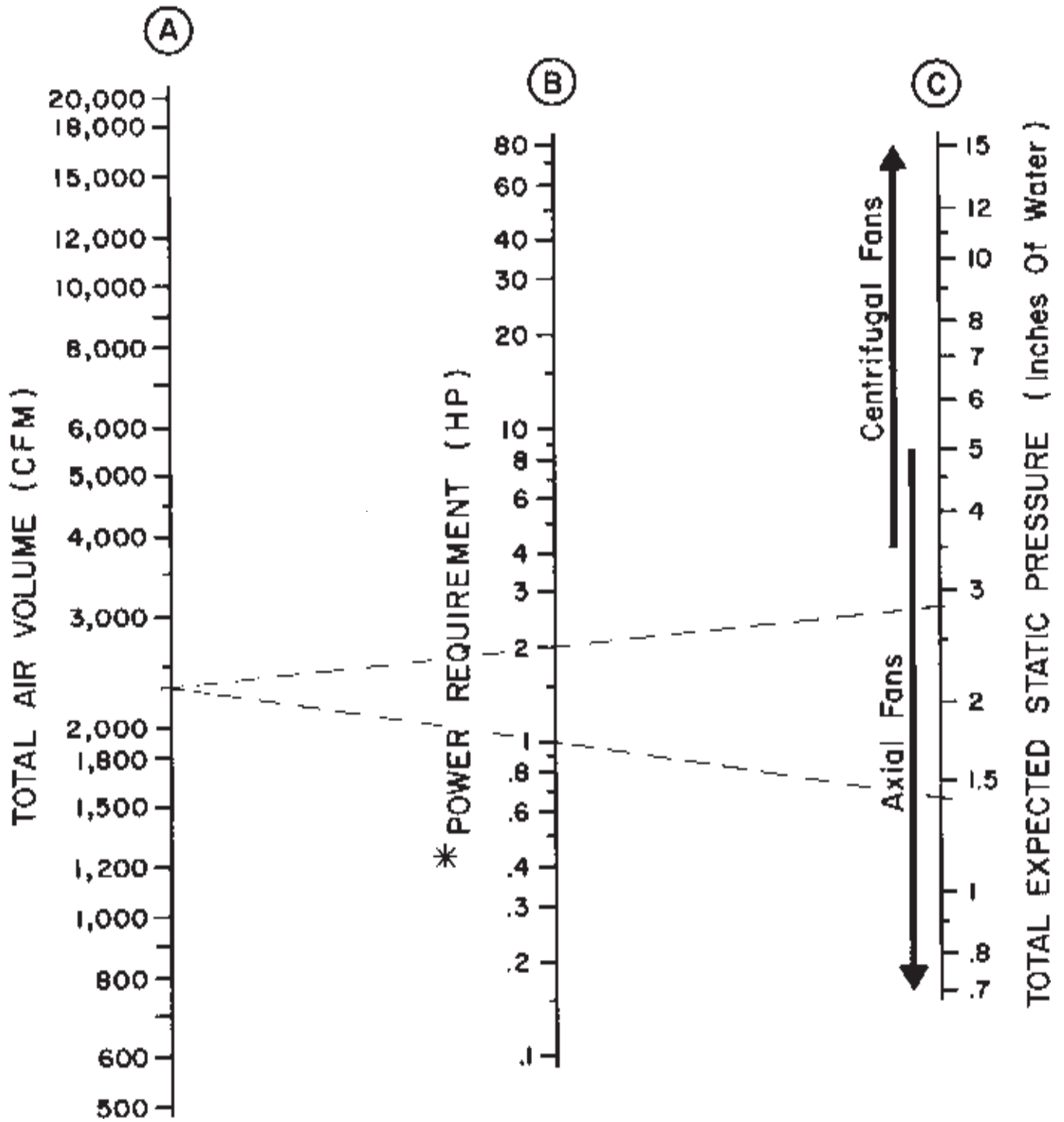

Nomograph 4. Approximate power requirement. *Assuming 50 percent efficiency.

be used, duct area requirements do not apply. Nomograph 3 gives 4 inches of static pressure for .5 CFM/bu, through 20 feet of grain sorghum using a perforated floor. From Nomograph 4, the approximate power requirement for 4,500 CFM at a static pressure of 4 inches is about 5.5 Hp

Other Considerations

Aeration systems should operate as pressure systems-flowing air upward through the grain. For a complete discussion, see Fact Sheet 1101.

There must be sufficient roof openings to allow the air to escape. The required air escape area, in square feet, is determined by dividing the total volume by 1,500 fpm. If the bin roof is mounted off the sidewall, the slot under the eaves serves as air escape area. When additional area is required, roof vents should be installed until the air escape area requirement is met.

When aeration systems are operating, the unloading auger tube should be sealed to prevent the escape of air.

Smooth transitions should be used to connect fan outlets with duct inlets. Sudden expansions and contractions should be avoided.

Some recently constructed grain systems utilized two axial fans of the same model installed in series (bolted end-

to-end). This practice allows axial fans to be used at static pressures which would normally require centrifugal fans. Two fans installed in series will deliver the same volume of air as a single fan at a static pressure 1.8 to 2.0 times that of the single fan.

Notes to Engineers

All static pressures are projected as Shedd's data x 1.0. Field measurements of operating static pressure confirm the validity of this assumption. Special cases of compaction or fine foreign material may necessitate an increase in projected operating pressure.

A ducting pressure loss of 0.5 inches is assumed in all cases. In addition, static pressure loss due to duct distribution is estimated at 0.5 inches for corn or soybeans and at 1.0 inches for wheat, grain sorghum, oats, barley, or rye. These values are appropriate when duct exit velocity is limited to 25 fpm.

All systems are assumed to be pressure systems which force air upward through the grain. Since duct velocity is limited to 1,500 fpm, static regain is assumed to equal friction loss in the duct. Very rough ducts may produce friction losses in excess of static regain.